

LED Strip

DigiStrip-60

dynamic and static effects in any colour



LED Strip

DigiStrip-60

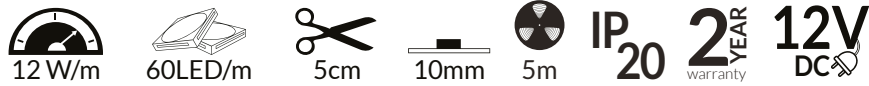

- **programmable** RGB LED strip with WS2811 chips
- **dynamic and static effects** in any colour
- high quality **selected SMD diodes** with long life span
- **2-layer PCB** substrate for high protection against overheating
- easy mounting thanks to **3-pin JST connectors** on both sides of the strip
- **3M** double-sided adhesive tape
- for **indoor use**

DIMENSIONS

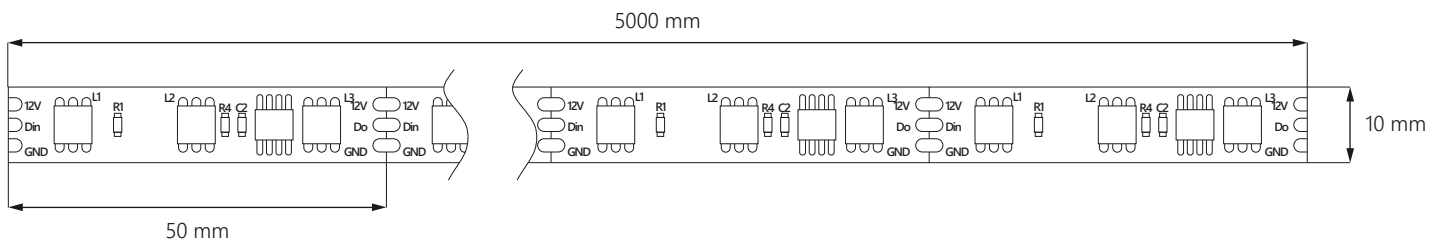

TECHNICAL SPECIFICATION

| | |
|------------------------------|--|
| Input voltage | 12V DC |
| Nominal power usage | 12 W/m |
| Max power section | 5 m |
| Colour rendering index | >58 |
| Beam angle | 120° |
| Dimmable with PWM controller | NO |
| Strip width | 10 mm |
| Cutting section | 5 cm |
| Reel length | 5 m |
| Type of diode | 3in1 SMD5050 + WS2811 |
| Density | 60 LED/m |
| PCB | 2 oz |
| Installation | double-sided adhesive tape + mounting glue |
| Lifespan | ~50000 hours |
| Working temperature | -20°C ÷ +40°C |
| IP rating | IP20 |
| Compliance with standards | CE / UKCA / RoHS / WEEE |
| Warranty | 2 years |

COLOURS

| Light colour | R/G/B wavelengths [nm] | Luminous flux [lm/m] | Luminous efficacy [lm/W] | Energy class |
|--------------|-----------------------------|----------------------|--------------------------|--------------|
| RGB | λ - 622 / 521 / 465 | 169 | 13 | G |

EPREL

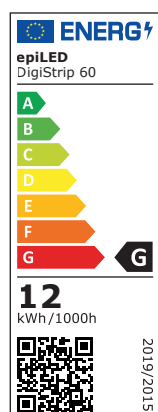

MAXIMUM POWER SECTION

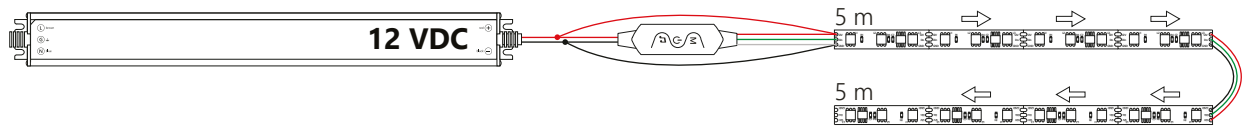
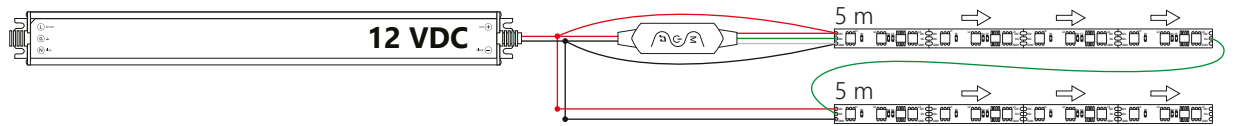

CONNECTION DIAGRAM

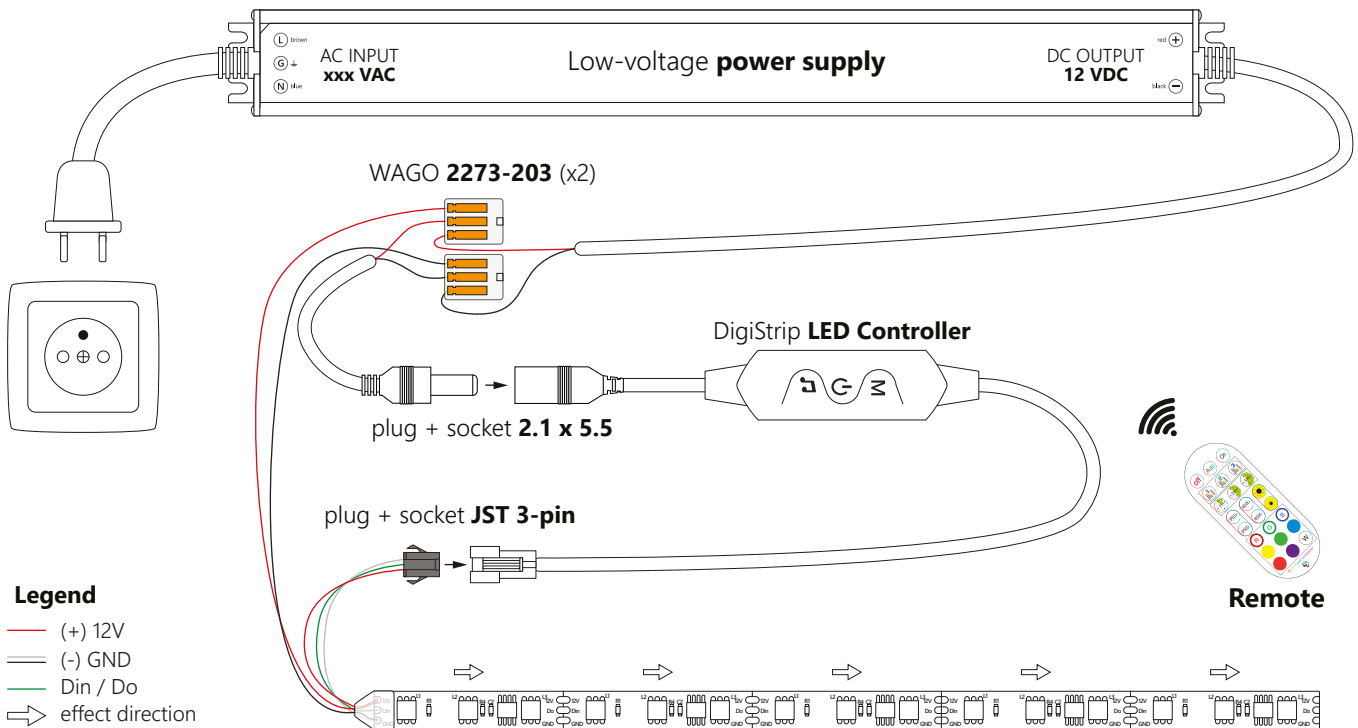

TERMS AND CONDITIONS OF USE

1. Each LED strip is packed in an anti-static bag to protect the LEDs from damage. Unused strip must not be outside the bag.
2. Before installing the LED strip, dissipate the charges from the body and clothing by touching the grounded metal part.
3. Check the proper operation of the LED strip before installation (its colour and uniformity of light).
4. LED strip is not suitable for outdoor use (regardless of the declared degree of IP rating) and can not be used in areas exposed to direct weather and human exposure.
5. To preserve the lifespan of LED strips should be mounted only on surfaces that dissipate heat well (such as aluminum profiles) previously degreased and cleaned.
6. Supply the LED strip according to the specifications and information on the label. Pay special attention to the maximum strip power section specified in the product data sheet.
7. When shortening the LED strip, remember that you can only cut it in the places marked on the backing.
8. It is forbidden to bend the LED strip in a different angle than the one in which it was wound on the reel.
9. The distance between the LED strip and the power supply should be as small as possible.
10. The power supply used in the installation should have a power reserve of not less than 15%.
11. Before soldering the wire to the LED strip, whitewash the ends first. LEDs are very sensitive to high temperatures and incompetent soldering can damage them.
12. For greater durability, in addition to double-sided adhesive tape, you should also use mounting glue when gluing the LED strip.
13. It is forbidden to press directly on the LEDs during installation.
14. When connecting the LED controller / power supply, it is necessary to maintain polarity.
15. **Non-compliance with the above recommendations will result in loss of warranty.**

DOWNLOAD

EU Declaration of Conformity

<https://www.epiled.pl/download/deklaracje/eu-declaration-of-conformity-led-strips.pdf>